

Rollbox

PRE-SORTING BINS



Dimensions

A	Total height in mm ~	554
B	Height in mm ~	454
C	Bin depth in mm ~	379
D	Total width in mm ~	493
E	Total depth in mm ~	427
F	Lid width in mm ~	410

Weights

Nominal volume (L)	45
--------------------	----

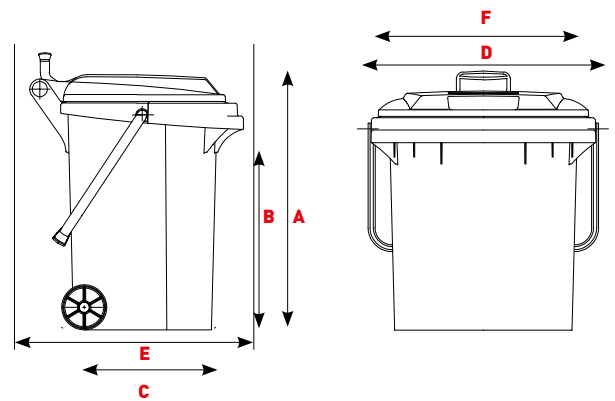

DESIGN AND MATERIAL

- Polymer components injection moulded from specially designed HDPE
- Resistant to decay, frost, heat and many chemicals
- Special UV-stabilisation provides excellent ageing characteristics
- Metal components are corrosion resistant
- Quiet-running solid rubber tyres
- Suitable for all DIN lifting equipment
- Compatible with identification and weighing systems
- Fitted as standard with chip nest in accordance with RAL GZ 951/1

QUALITY AND USAGE

- Certified according to EN 840 and RAL GZ 951/1
- Certified management systems according to DIN EN ISO 9001, DIN EN ISO 14001 and BS OHSAS 18001
- Constant supervision of quality through own laboratory and independent institutes
- High quality materials and most advanced manufacturing processes for long service life
- All container parts are recyclable
- Additives are cadmium free and environmentally friendly

SAFETY AND HANDLING

- Double angle rail for highest safety during emptying
- Safe and easy to manoeuvre
- Continuous handle on the body
- Special ribs prevent containers from becoming jammed when stacked
- Particularly stable due to external position of wheels
- Open wheel case prevents accumulation of dirt
- Easy to clean due to smooth surfaces and rounded internal corners
- No water ingress when opening the lid